

HDU - CO₂ TRANSMITTER/CONTROLLER FOR COLD SPACES

HDU transmitters are designed for detecting and controlling carbon dioxide concentration and temperature inside unheated places like parking halls. The transmitter information can be used for demand based ventilation control, for example.

The measurement values scroll on the N model display. The wanted value can be locked to view continuously.

ABCLogic™ self-calibration method eliminates the possible long term drift. The ABCLogic™ function can be turned off by using the ML-SER tool.

The control output can be controlled either according to a one measurement value or according to the maximum selection of all values. The controller settings can be changed by using the ML-SER tool.

The transmitter can be equipped with a HD-R relay (24 Vac, 1 A). The relay output can be controlled either according to a one measurement value or according to the all measured values. The relay switching point can be adjusted by using ML-SER tool.

Wiring:

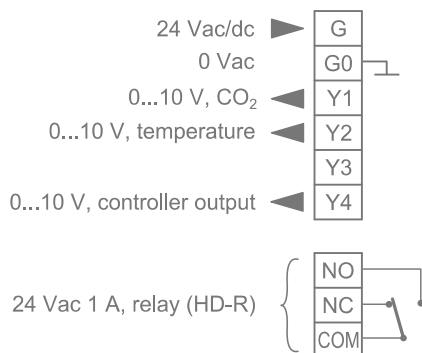

Technical data

Supply	24 Vac/dc (22...28 V) < 10 VA
Carbon dioxide measurement	
range	0...2000 ppm
accuracy (25 °C)	typ. ±40 ppm +3 % from reading (ABCLogic™)
long term stability/year	< 2 % FS (ABCLogic™)
time constant	< 2 min
Temperature measurement	
range	-50...50 °C
accuracy (25 °C)	±0.5 °C
Outputs	0...10 V < 2 mA
Operating conditions	
temperature	-30...50 °C
humidity	0...85 % RH (non cond.)
Housing	IP54
Dimensions (w x h x d)	105 x 110 x 46 mm

Ordering guide:

Model	Product number	Description
HDU	1135090	CO ₂ and °C transmitter for cold spaces
HDU-N	1135091	transmitter with display
HD-R	1135003	option, relay 24 Vac 1 A
ML-SER	1139010	transmitter commissioning tool

Products fulfil the requirements of directive 2004/108/EC and are in accordance with the standards EN61000-6-3: 2001 (Emission) and EN61000-6-2: 2001 (Immunity).